



Detroit **STEEL WHEEL CO.**



WWW.DETROITSTEELWHEEL.COM

810.333.6100



100%
MANUFACTURED
IN THE USA

OUR MISSION AT DETROIT STEEL WHEEL CO.

**OUR MISSION IS TO WORK HARD FOR OUR
CUSTOMERS BY RESTORING A CULTURE OF CARE,
COMMITMENT, AND PERSONAL INVESTMENT.**



**WE ARE DEDICATED TO DELIVERING QUALITY AND
VALUE THROUGH PRODUCTS THAT ARE FULLY
SOURCED AND MADE IN AMERICA-BUILT WITH PRIDE,
PERFORMANCE, AND INTEGRITY.**

D-TOWN

AVAILABLE SIZES	AVAILABLE BACKSPACING
NEW 18" X 7"	3.5", 3.75"
18" X 8"	3.5", 4.0", 4.5", 4.75"
18" X 9"	3.5", 4.0", 4.5", 5.0", 5.5", 5.75"
NEW 18" X 10"	3.5", 4.0", 4.5", 5.0", 5.5", 6", 6.5"
20" X 8"	3.5", 4.0", 4.5", 4.75"
20" X 9"	3.5", 4.0", 4.5", 5.0", 5.5", 5.75"
NEW 20" X 10"	3.5", 4.0", 4.5", 5.0", 5.5", 6", 6.5", 6.75"
20" X 11"	3.5", 4.0", 4.5", 5.0" 5.5", 6.0", 6.5", 7.0", 7.5"
NEW 20" X 14"	3.5", 4.0", 4.5", 5.0", 5.5", 6.0", 6.5", 7.0", 7.5", 8", 8.5", 9", 9.5", 10", 10.5"
22" X 9"	3.0", 3.5", 4.0", 4.5", 4.5"



Minimum and Maximum Backspaces listed



AVAILABLE LUG PATTERNS

- Dual lug pattern wheel: Small 5: 5x4.5" & 5x4.75" (Center bore 3.18")
- 5x5" Lug wheel (Center bore 3.74")
- 5x5.5" Lug wheel (Center bore 4.275")
- 6x5.5" Lug wheel (Center bore: 4.275")
- 8x6.5" Lug wheel (Center bore: 5.15")
- 8x170mm Lug Wheel (Center bore: 5.15") **NEW**

AMBASSADOR

AVAILABLE SIZES	AVAILABLE BACKSPACING
NEW 18" X 7"	3.5", 3.75"
18" X 8"	3.5", 4.0", 4.5", 4.75"
18" X 9"	3.5", 4.0", 4.5", 5.0", 5.5", 5.75"
NEW 18" X 10"	3.5", 4.0", 4.5", 5.0", 5.5", 6", 6.5"
20" X 8"	3.5", 4.0", 4.5", 4.75"
20" X 9"	3.5", 4.0", 4.5", 5.0", 5.5", 5.75"
NEW 20" X 10"	3.5", 4.0", 4.5", 5.0", 5.5", 6", 6.5", 6.75"
20" X 11"	3.5", 4.0", 4.5", 5.0" 5.5", 6.0", 6.5", 7.0", 7.5"
NEW 20" X 14"	3.5", 4.0", 4.5", 5.0" 5.5", 6.0", 6.5", 7.0", 7.5", 8", 8.5", 9", 9.5", 10", 10.5"
22" X 9"	3.0", 3.5", 4.0", 4.5", 4.5"

Minimum and Maximum Backspaces listed



AVAILABLE LUG PATTERNS

- Dual lug pattern wheel: Small 5: 5x4.5" & 5x4.75" (Center bore 3.18")
- 5x5" Lug wheel (Center bore 3.74")
- 5x5.5" Lug wheel (Center bore 4.275")
- 6x5.5" Lug wheel (Center bore: 4.275")

DELRAYS

AVAILABLE SIZES	AVAILABLE BACKSPACING
NEW 18" X 7"	3.5", 3.75"
18" X 8"	3.5", 4.0", 4.5", 4.75"
18" X 9"	3.5", 4.0", 4.5", 5.0", 5.5", 5.75"
NEW 18" X 10"	3.5", 4.0", 4.5", 5.0", 5.5", 6", 6.5"
20" X 8"	3.5", 4.0", 4.5", 4.75"
20" X 9"	3.5", 4.0", 4.5", 5.0", 5.5", 5.75"
NEW 20" X 10"	3.5", 4.0", 4.5", 5.0", 5.5", 6", 6.5", 6.75"
20" X 11"	3.5", 4.0", 4.5", 5.0" 5.5", 6.0", 6.5", 7.0", 7.5"
NEW 20" X 14"	3.5", 4.0", 4.5", 5.0", 5.5", 6.0", 6.5", 7.0", 7.5", 8", 8.5", 9", 9.5", 10", 10.5"
22" X 9"	3.0", 3.5", 4.0", 4.5", 4.5"

Minimum and Maximum Backspaces listed



AVAILABLE LUG PATTERNS

- Dual lug pattern wheel: Small 5: 5x4.5" & 5x4.75" (Center bore 3.18")
- 5x5" Lug wheel (Center bore 3.74")
- 5x5.5" Lug wheel (Center bore 4.275")
- 6x5.5" Lug wheel (Center bore: 4.275")
- 8x6.5" Lug wheel (Center bore: 5.15")
- 8x170mm Lug Wheel (Center bore: 5.15") **NEW**

MACK

AVAILABLE SIZES	AVAILABLE BACKSPACING
NEW 18" X 7"	3.5", 3.75"
18" X 8"	3.5", 4.0", 4.5", 4.75"
18" X 9"	3.5", 4.0", 4.5", 5.0", 5.5", 5.75"
NEW 18" X 10"	3.5", 4.0", 4.5", 5.0", 5.5", 6", 6.5"
20" X 8"	3.5", 4.0", 4.5", 4.75"
20" X 9"	3.5", 4.0", 4.5", 5.0", 5.5", 5.75"
NEW 20" X 10"	3.5", 4.0", 4.5", 5.0", 5.5", 6", 6.5", 6.75"
20" X 11"	3.5", 4.0", 4.5", 5.0" 5.5", 6.0", 6.5", 7.0", 7.5"
NEW 20" X 14"	3.5", 4.0", 4.5", 5.0", 5.5", 6.0", 6.5", 7.0", 7.5", 8", 8.5", 9", 9.5", 10", 10.5"
22" X 9"	3.0", 3.5", 4.0", 4.5", 4.5"



Minimum and Maximum Backspaces listed



AVAILABLE LUG PATTERNS

- Dual lug pattern wheel: Small 5: 5x4.5" & 5x4.75" (Center bore 3.18")
- 5x5" Lug wheel (Center bore 3.74")
- 5x5.5" Lug wheel (Center bore 4.275")
- 6x5.5" Lug wheel (Center bore: 4.275")

JOHN R

AVAILABLE SIZES	AVAILABLE BACKSPACING
NEW 18" X 7"	3.5", 3.75"
18" X 8"	3.5", 4.0", 4.5", 4.75"
18" X 9"	3.5", 4.0", 4.5", 5.0", 5.5", 5.75"
NEW 18" X 10"	3.5", 4.0", 4.5", 5.0", 5.5", 6", 6.5"
20" X 8"	3.5", 4.0", 4.5", 4.75"
20" X 9"	3.5", 4.0", 4.5", 5.0", 5.5", 5.75"
NEW 20" X 10"	3.5", 4.0", 4.5", 5.0", 5.5", 6", 6.5", 6.75"
20" X 11"	3.5", 4.0", 4.5", 5.0", 5.5", 6.0", 6.5", 7.0", 7.5"
NEW 20" X 14"	3.5", 4.0", 4.5", 5.0", 5.5", 6.0", 6.5", 7.0", 7.5", 8", 8.5", 9", 9.5", 10", 10.5"
22" X 9"	3.0", 3.5", 4.0", 4.5", 4.5"

Minimum and Maximum Backspaces listed



AVAILABLE LUG PATTERNS

- Dual lug pattern wheel: Small 5: 5x4.5" & 5x4.75" (Center bore 3.18")
- 5x5" Lug wheel (Center bore 3.74")
- 5x5.5" Lug wheel (Center bore 4.275")
- 6x5.5" Lug wheel (Center bore: 4.275")

810.333.6100



4X4

Detroit Steel Wheel Co. delivers modern style and proven strength for your off-road build. Whether you're tackling the trail or upgrading your daily driver with that perfect look our wheels are built to handle it all.

Wider sizes available perfect for oversized off-road tires and aggressive stances.

Not sure about fitment?

Our crew is here to help. We'll walk you through the process and make sure your setup is dialed in.



WWW.DETROITSTEELWHEEL.COM

810.333.6100



MUSCLE CARS

Detroit Steel Wheels give your muscle car the perfect stance, an aggressive attitude, and—best of all—a look that feels like it belongs. Proudly built and sourced in the USA, Detroit Steel Wheels represent true American craftsmanship with authentic, retro-inspired designs. Whether you're restoring a classic or building a pro-touring beast, our range of finishes and trim options make it easy to dial in the exact stance you want, giving your ride the muscle-bound presence it deserves. Detroit Steel Wheels aren't just wheels—they're a bold statement of heritage, performance, and all-American pride.

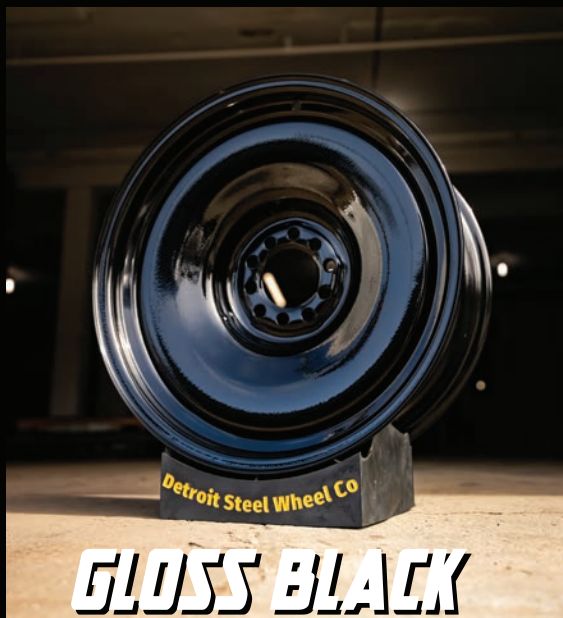

PHOTO SHOT BY STANCE IS EVERYTHING

WWW.DETROITSTEELWHEEL.COM

WHEEL POWDER COAT OPTIONS

810.333.6100



GLOSS BLACK



LOW GLOSS BLACK

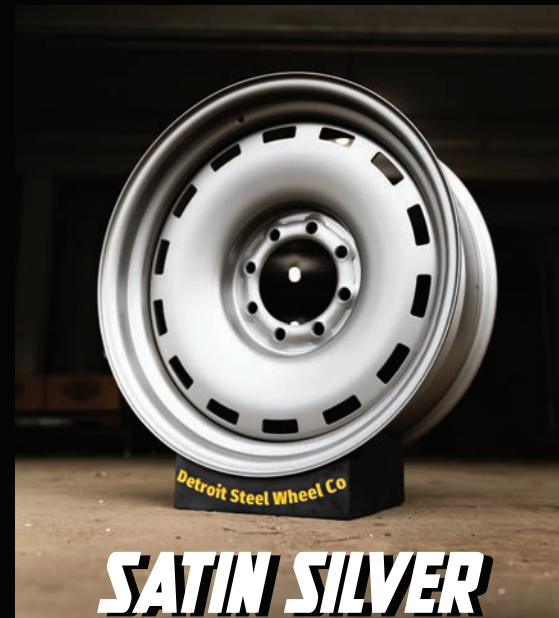

SATIN SILVER



9010 GLOSS WHITE



9010 LOW GLOSS WHITE



BRIGHT WHITE

PINSTRIPING

810.333.6100



“A Signature”

Not a sticker. Not a machine.
Just a steady hand and an eye for detail.

A subtle reminder that real craftsmanship still exists —
the kind that separates the ordinary from the unforgettable.

A signature of care and quality.
Proudly made in the USA.

WWW.DETROITSTEELWHEEL.COM

PINSTRIPING

810.333.6100



ALPHA WHITE	ALPHA RED PMS - 200 C	WINE PMS - 188 C
LIGHT GREY PMS 422 C	DARK PINK PMS 198 C	DARK RED PMS - 7427 C
ALPHA GREY PMS - 423 C	HOT PINK PMS - 2029 C	OXIDE PMS - 7624 C
DARK GREY PMS - 11 C	RASPBERRY SHERBET PMS - 701 C	VERMILION PMS - 166 C
MCKEAG'S BLACK	BLACKBERRY SHERBET PMS - 531 C	BURNT ORANGE PMS - 471 C
DARK OLIVE PMS - 574 C	VIOLET PMS - 521 C	BLOOD ORANGE PMS - 1665 C
CHOCOLATE BROWN PMS - 476 C	ALPHA PURPLE PMS - 273 C	ALPHA ORANGE PMS - 3564 C
MEDIUM BROWN PMS - 4625 C	MEYER'S DARK BLUE PMS - 655 C	ORANGE SHERBET PMS - 1485 C
ARMY GREEN PMS - 7770 C	ALPHA BLUE PMS - 3506 C	BLUSH PMS - 148 C
CHARTREUSE PMS - 456 C	LIGHT BLUE PMS - 2383 C	TAN PMS - 7508 C
OLIVE PMS - 384 C	BABY BLUE PMS - 2915 C	DARK YELLOW PMS - 7549 C
ALPHA GREEN PMS - 7726 C	BLUEBERRY SHERBET PMS - 2905 C	IMITATION GOLD PMS - 110 C
MONSTER GREEN PMS - 2424 C	AQUA PMS - 3248 C	ALPHA YELLOW PMS - 7405 C
DORR'S GREEN PMS - 2299 C	LIGHT TEAL PMS - 231 C	LIQUID SUNSHINE PMS - 113 C
MINT PMS - 344 C	DARK TEAL PMS - 2223 C	LEMON SHERBET PMS - 460 C
JADEITE PMS - 564 C	BRIGHT TEAL PMS - 2230 C	IVORY PMS - 7401 C
ELECTROSHOCK PINK PMS - 806 C	ELECTROSHOCK RED PMS - 805 C	ELECTROSHOCK ORANGE PMS - 804 C
ELECTROSHOCK YELLOW PMS - 803 C	ELECTROSHOCK GREEN PMS - 802 C	ELECTROSHOCK BLUE PMS - 801 C

METALLIC GOLD	METALLIC SILVER
MERMAID Color changing paint	SUNSET Color changing paint

7.5" SNAP-IN CAPS

- Works with 5 and 6 lug wheels
- Applies to all style wheels



CHROME BABY MOON



CHROME SHANNON CONE



CHROME PLAIN RALLY



SHANNON CONE



PLAIN RALLY



BABY MOON

WHEEL ACCESSORIES

810.333.6100



10.25" ID DOG DISH CAPS

- Works with 5 & 6 lug wheels optioned with drill, tap, and install clip service.



F1025-1



F1025-2



C1025-1



C1025-2



F1025-3R



F1025-3W



C1025-3W



C1025-3B

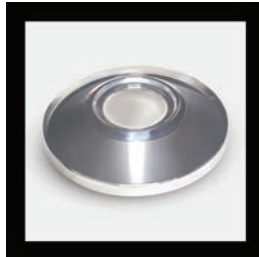

F1025-3-OPEN



BABY MOON
DOG DISH



FC1025-1 OPEN
OPEN 4X4 HUBCAP



A-DD TEMPLATE
10.25" ID CAP DRILL INSTALLATION KIT



CLIPS SET OF 5



A-DD TEMPLATE
12" CAP DRILL INSTALLATION KIT

DRILL, TAP AND INSTALL CLIPS SERVICE:
If you have your own dog dish/ poverty caps, wheels can be optioned with the drill and tap service.

- Caps must measure 8.75" 12" for 5 & 6 Lug Wheels
- Caps must measure 12" for 8 Lug Wheels

DRILL, TAP AND INSTALLATION KIT:
Install your own with our template, punch, drill and tap.



WHEEL CLIP SET

- 5 clips per wheel.
- Clips will not be installed on raw wheels unless requested.

810.333.6100



DOG



DISH

BOLT-ON CAPS

- Works with 5 and 6 lug wheels
- Applies to all style wheels

CHROME/ PLASTIC FINISH



**6 LUG SPIDER
FITS 6X5.5 ONLY**

CHROME FINISH



**BULLET PUSH THRU
FITS 5X4.5 & 5X4.75 ONLY**



5X5 LUG CHEVY



6X5.5 LUG CHEVY



6X5.5 LUG 4x4 OPEN

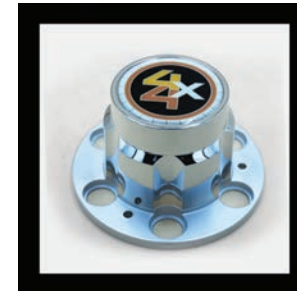

6X5.5 LUG 4x4 CLOSED



5X5 LUG GMC



5X5.5 LUG FORD OPEN



5X5.5 LUG FORD RED



5X5.5 LUG FORD RED

PUSH THROUGH & LUG CAPS-O.D. 5.15"

- Works with 8 lug wheels only
- Colors: Chrome or Matte Black
- Lengths: 3.5", 4.5", and 6.5"
- Style: All lengths available in closed style
- Open style available *only* in 4.5" length



4.5" CHROME OPEN



4.5" MATTE BLACK OPEN



3.5" MATTE BLACK



4.5" MATTE BLACK



6.5" MATTE BLACK



3.5" CHROME



4.5" CHROME



6.5" CHROME

LUG NUTS & TRIM RINGS



BULLET LUG NUT

- 7/16
- 1/2 - 20
- 12mm x 1.5
- 14mm x 1.5



ACORN BULGE NUT

- 7/16
- 1/2 - 20
- 9/16
- 12mm x 1.5
- 14mm x 1.5



DUPLEX ACORN NUT 1.88" TALL

- 7/16
- 1/2 - 20
- 9/16
- 14mm x 1.5



STAINLESS STEEL TRIM RINGS

18" and 20"

- Applies to all style wheels



Measuring Backspace

Backspacing is a key measurement used to determine the position of a wheel and tire assembly when it's put onto the vehicle's wheel mounting surface. Specifically, it refers to the distance from the mounting surface of the wheel—the part that makes contact with the hub—to the back lip of the wheel. This measurement plays a significant role in how the wheel sits in relation to the vehicle's suspension and body.

When it comes to placement, a wheel with a higher backspacing value will sit further inward/vehicle side, bringing it closer to the suspension components. On the other hand, a lower backspacing value means the wheel will sit further outward/curbside, which can cause it to extend past the fender line.

Understanding and selecting the proper backspacing is important for several reasons. First, it ensures there's enough clearance between the wheel and the suspension parts, as well as between the tire and the vehicle's body. Second, it influences the vehicle's stance, which affects both aesthetics and handling. Lastly, correct backspacing is essential for proper fitment, helping to avoid issues like rubbing or poor alignment that could lead to premature wear or safety concerns.

Ex: 5.75" Back Space

**Wheel Mounting Surface
Contact Point**

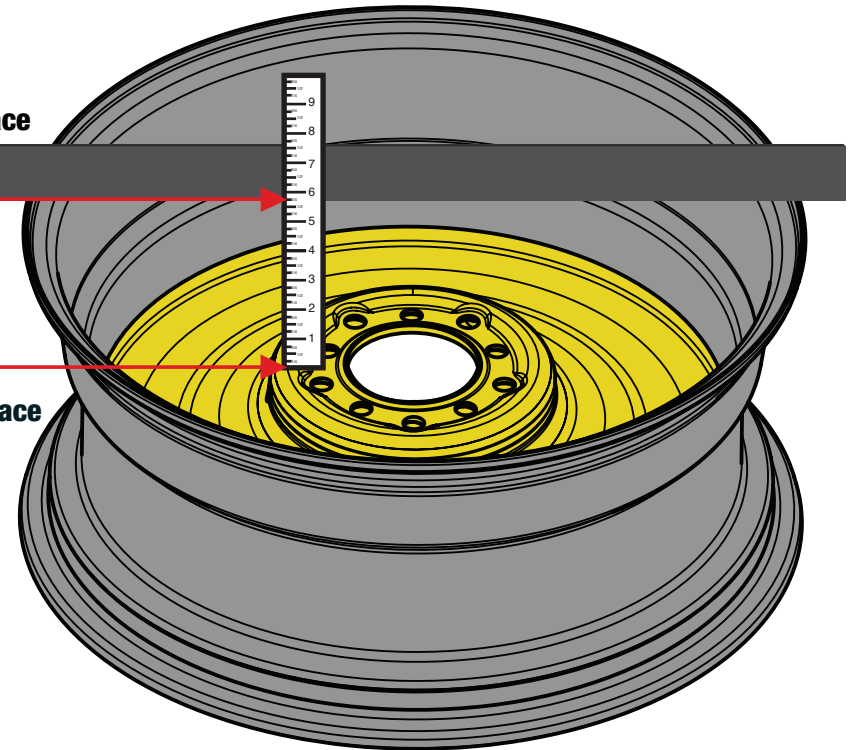

Ex: 20x9" Wheel

Bolt Pattern

There are four common wheel patterns: four-lug, five-lug, six-lug, and eight-lug. The measurement method varies depending on the pattern.

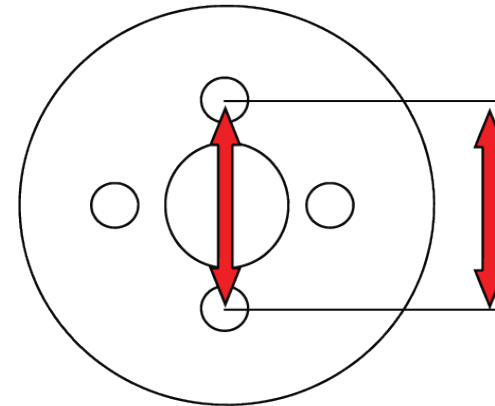

Four Lug Measure from the center of any two bolt holes that are directly opposite each other.

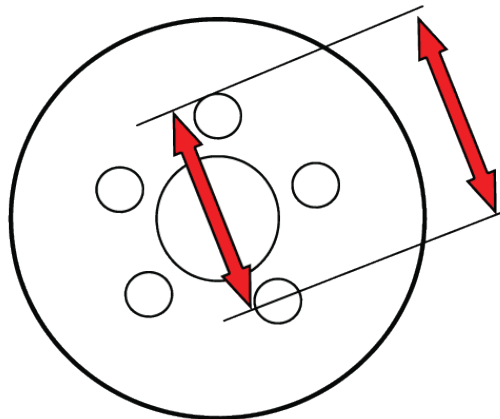

Five Lug Select two non-adjacent bolt holes and measure from the back of the first hole to the center of the second hole.

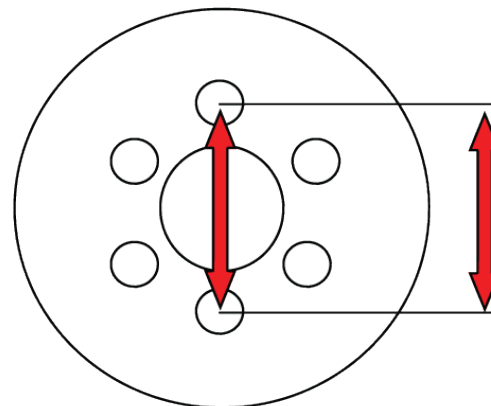

Six Lug Measure from the center of two holes that are directly opposite each other.

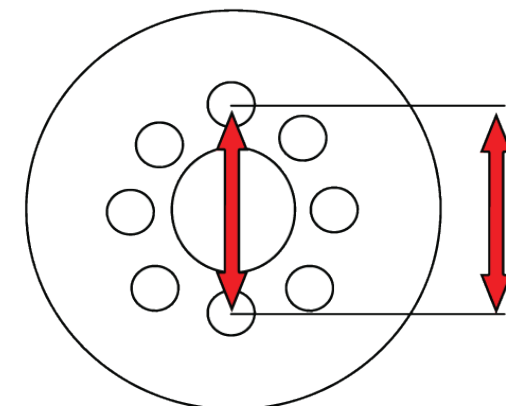

Eight Lug Measure from the center of two holes directly opposite each other.

WHEEL MEASURING: 20X9" RIM

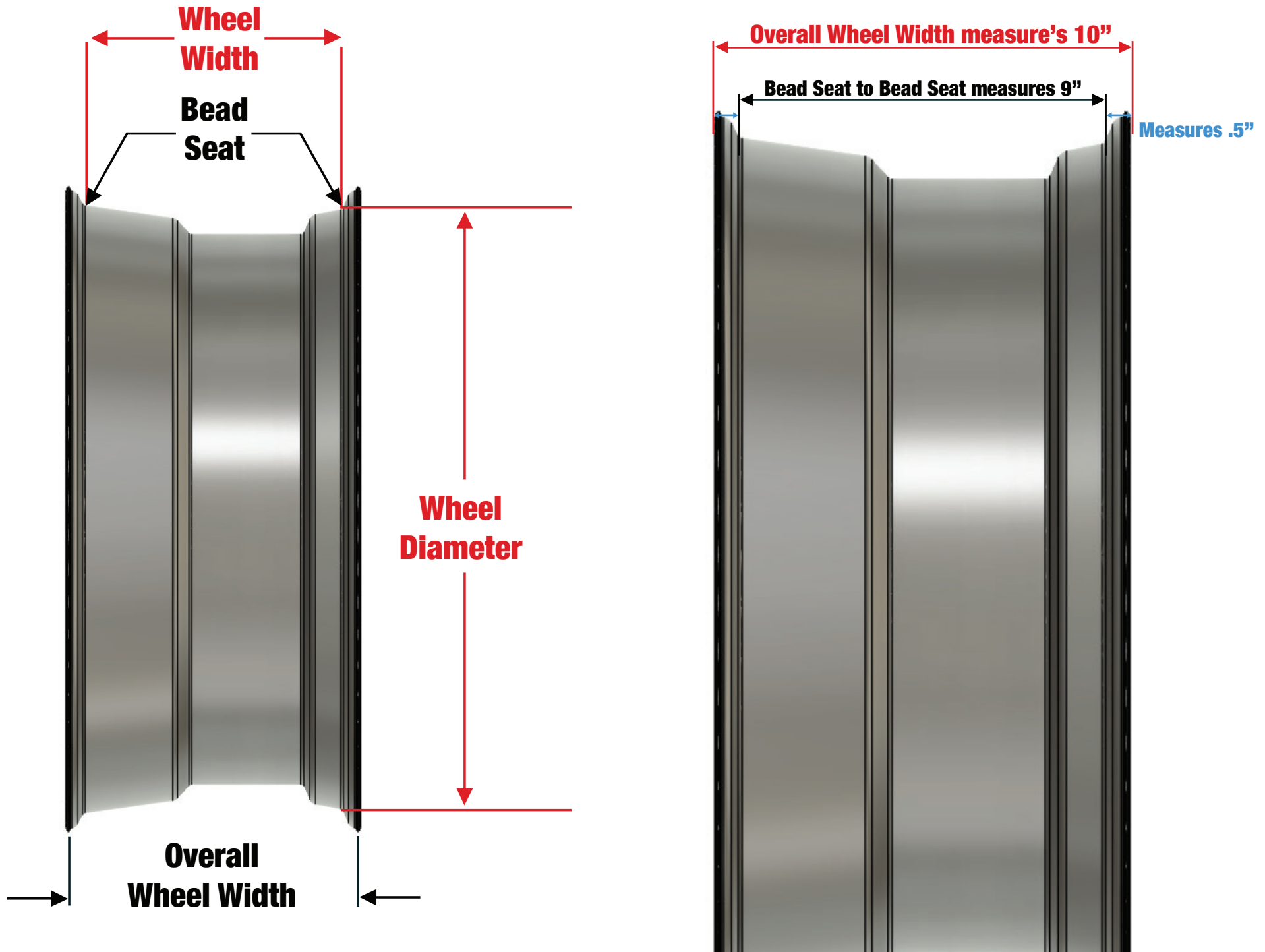



3.5" Back Space

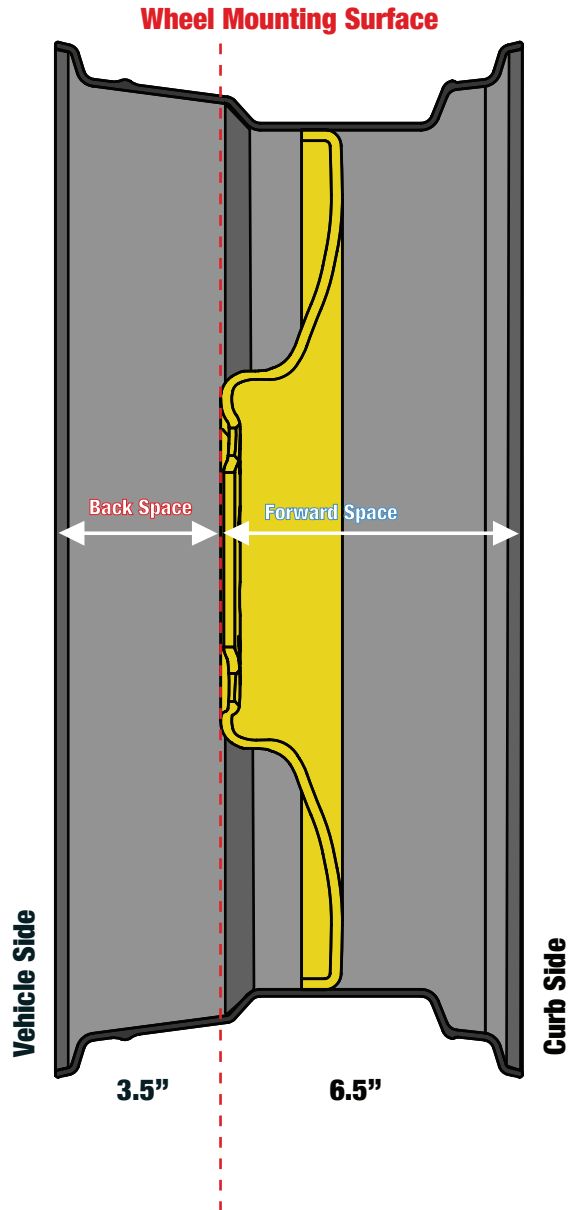

5" Back Space

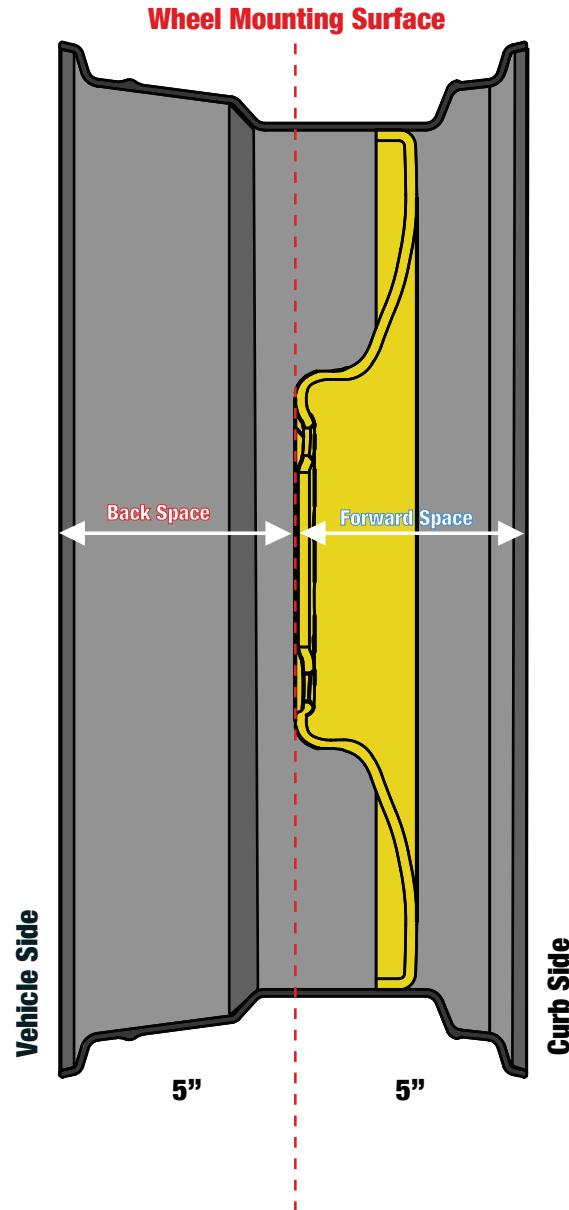

5.75" Back Space

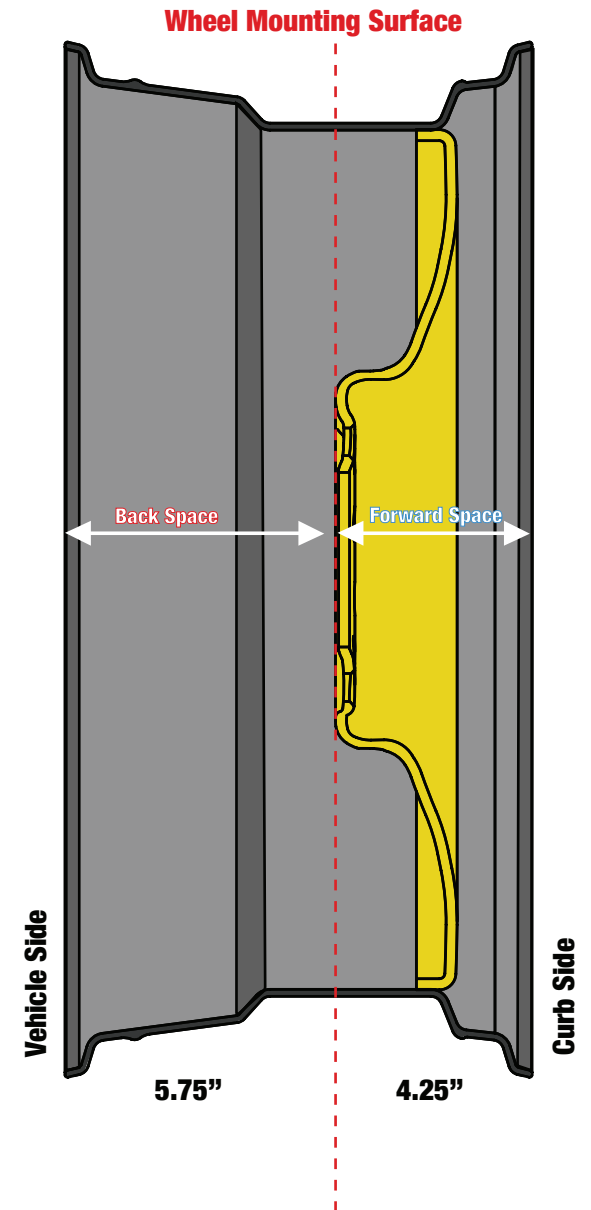

MEASURING GUIDE FOR FRONT WHEEL FITMENT 810.333.6100



Wheel Mounting Surface The area on the wheel that directly contacts the vehicle's hub or brake drum.

Caliper Overhang The distance the face of the brake caliper extends beyond the wheel mounting surface.

Back Space The measurement from the mounting surface towards vehicle side, stopping at the first point the wheel would make contact.

Front Space The measurement from the mounting surface towards curb side, stopping at the inner fender.

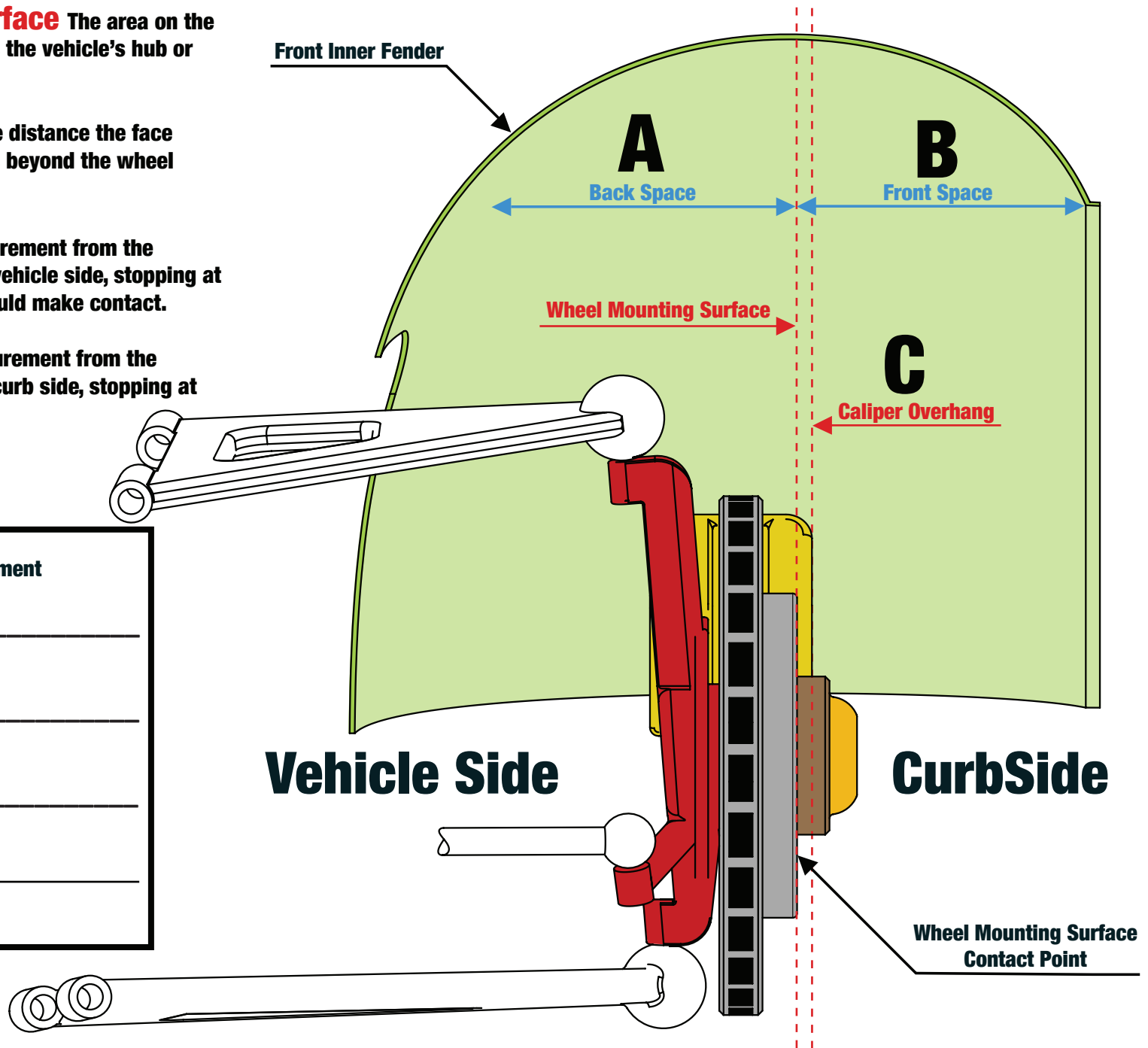

Front Wheel Fitment	
A :	_____
Back Space	
B :	_____
Front Space	
C :	_____
Caliper Overhang	
D :	_____
Bolt Pattern	

MEASURING GUIDE FOR REAR AXEL WHEEL FITMENT 810.333.6100



Rear Axel Wheel Fitment

A : _____
Back Space

B : _____
Front Space

C : _____
Caliper Overhang

D : _____
Bolt Pattern

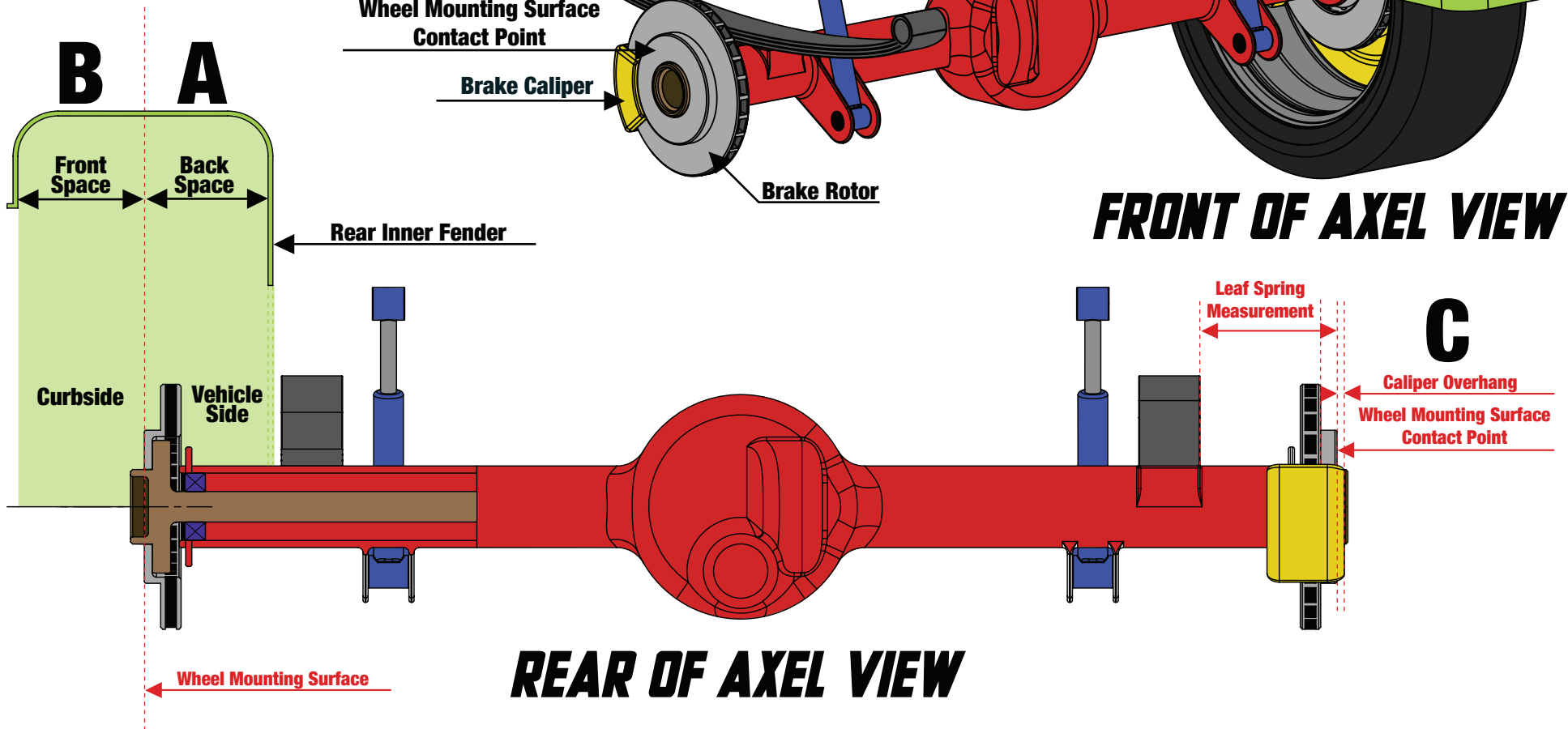
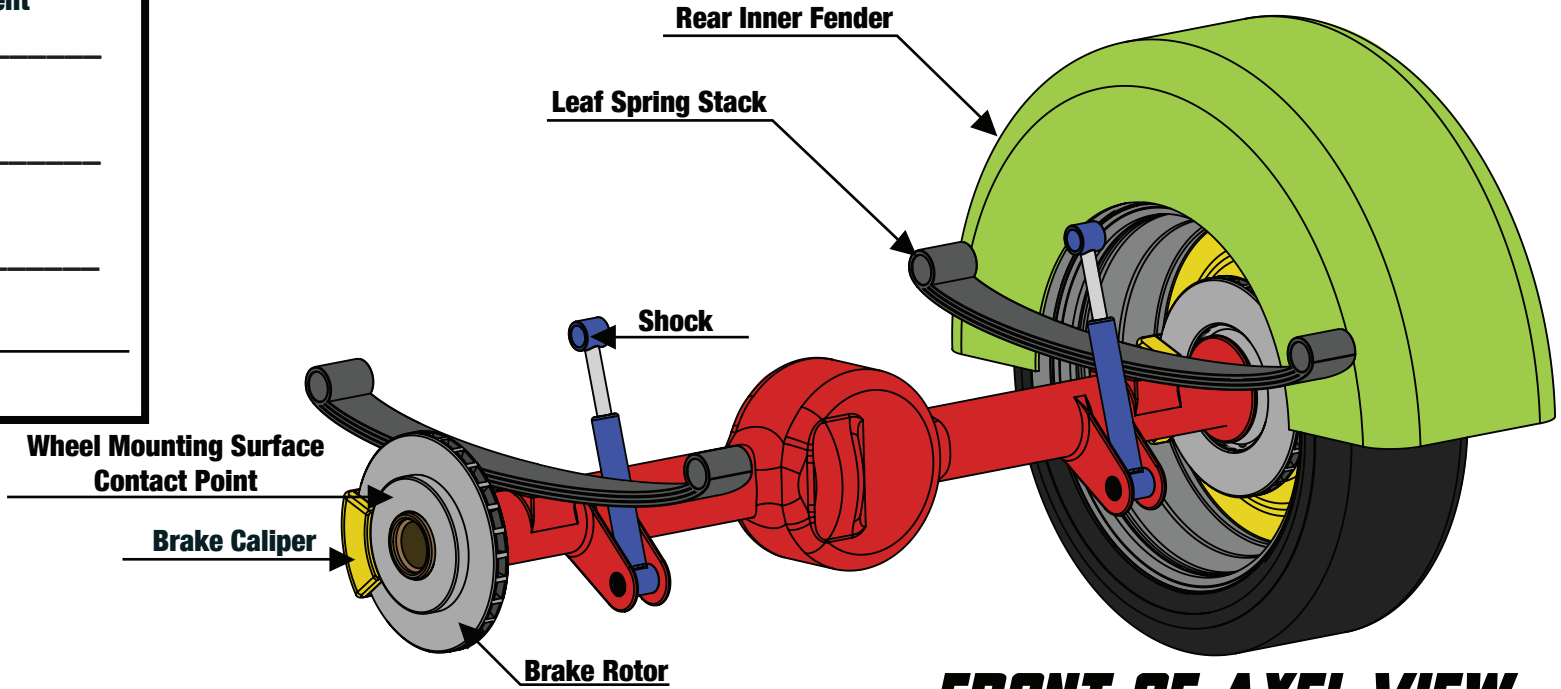

Detroit STEEL WHEEL CO.

QUESTIONS TO CONSIDER FOR THE RIGHT FITMENT OF YOUR CUSTOM WHEELS:

- 1.** Is the vehicle bagged, lowered or stock ride height?
- 2.** Does your vehicle have fender skirts?
- 3.** Does the shape of your fender change or narrow at the top of the wheel well?
- 4.** What size tires do you want to run and do those specs work with your wheel specs?
- 5.** What is your current tire size?
- 6.** What is your available overall height (wheel & tire)?
- 7.** Will your new wheels clear your fender lip on the front and backside when you turn the steering wheel lock to lock?
- 8.** How far out does your hub stick out (cap fitment)?
- 9.** Do you want to be able to rotate your wheels?
- 10.** What other modifications have been made to the vehicle? i.e. C-notch, tubbed, different chassis, different front or rear axles, narrowed axles, rolled fender lip, changed lug pattern, disc brake conversion, wheel spacers or adapters, etc.





THE LEADER IN LARGE DIAMETER STEEL WHEELS

Detroit **STEEL WHEEL CO.**

CALL US AT 810.333.6100 OR EMAIL SALES@DETROITSTEELWHEEL.COM

WWW.DETROITSTEELWHEEL.COM